



## **ISOPERFECT SYSTEM**

**LOADING AND UNLOADING SYSTEM FOR FREEZING LOADING BAYS**



*Since 1967*

*Reliable Doors & Docks*

[www.angelmir.com](http://www.angelmir.com)

# ISOPERFECT System

The Isoperfect System allows the opening of the truck doors inside the refrigerated building, avoiding loss of temperature and contaminations (dust, fumes, insects, etc), as well as risks for the driver. It provides an insulated and isothermal loading dock, therefore keeping intact the cold chain in the logistics platforms of the food industries.

## How does it work?

A SINGLE control panel for all the loading bay equipment

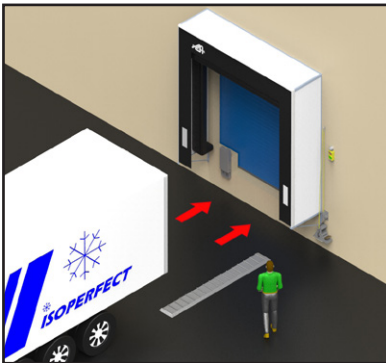

1. The external traffic light on green indicates that the dock is ready for its use. The truck approaches the dock with the back doors closed.

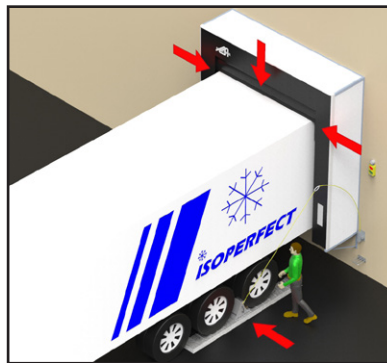

2. Once the truck is placed, the driver must chock the wheel of the truck to allow the inflatable shelter to seal it.

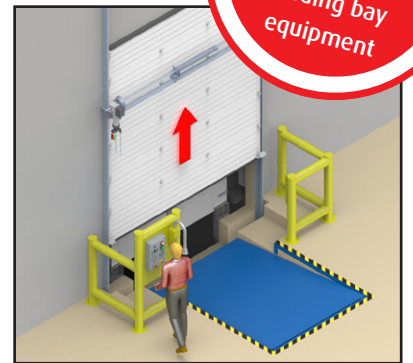

3. When the truck is sealed by the inflatable shelter, the door is automatically opened and the Versalight turned on.

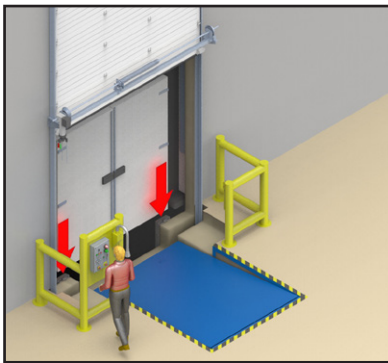

4. The operator must push down the bumpers.

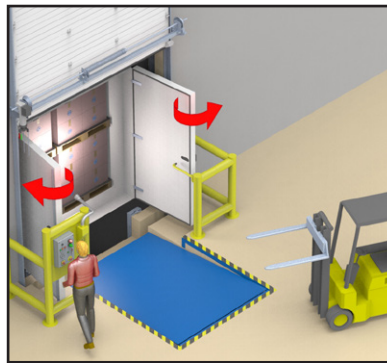

5. The operator opens the back door of the truck.

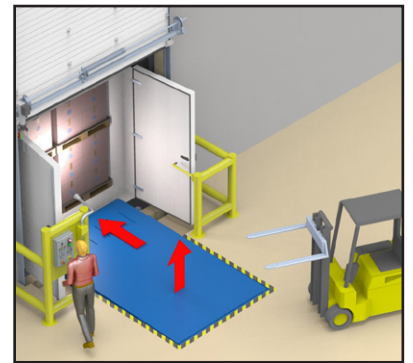

6. The operator locates the lip of the telescopic dock leveler over the truck.

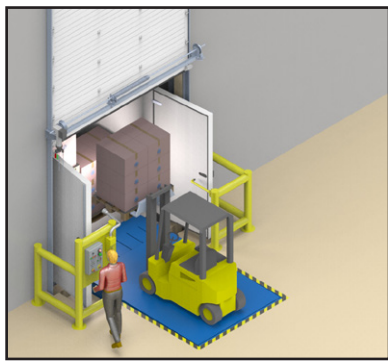

7. Everything is ready and safe for the loading / unloading process of the truck.

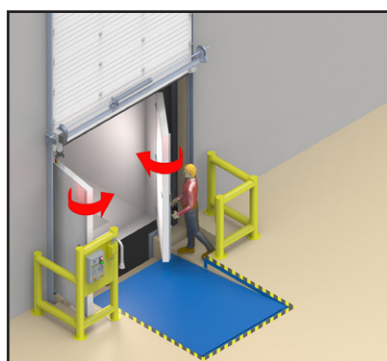

8. Once the process is done, the opposite process takes place.



APPROPRIATE LOADING / UNLOADING SYSTEM TO FULFILL IFS & BRC FOOD SAFETY CERTIFICATIONS

# ISOPERFECT Plus System

Isoperfect Plus System includes the new sealing cushion AH 4BAGS at below. This inflatable dock shelter seals completely all around the truck with high insulation.

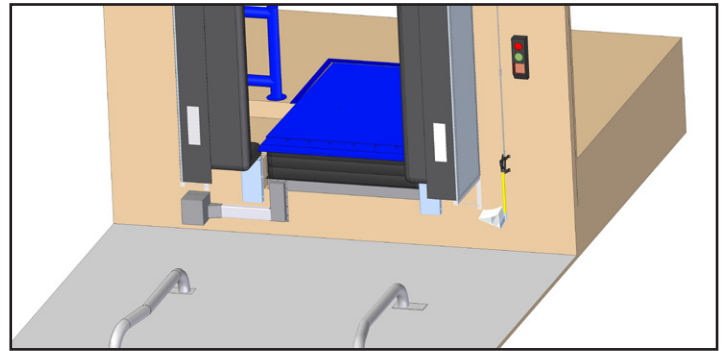
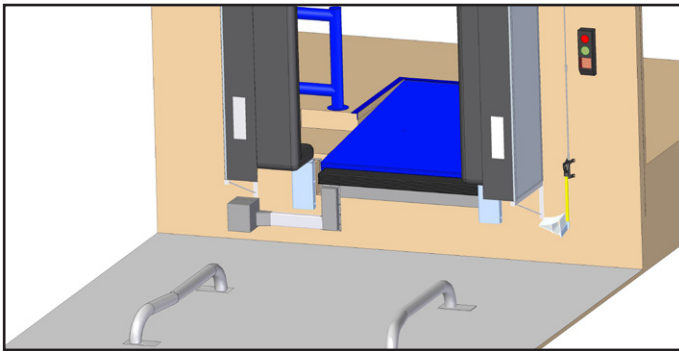
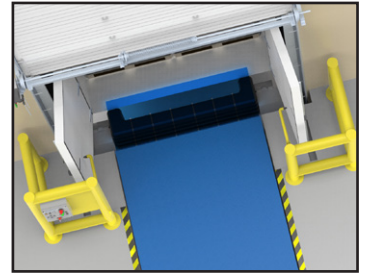

# ISOPERFECT Eco System

Isoperfect ECO System differs by having a vertical loading dock KA Hidra instead of the telescopic dock leveller, which makes it a more economical system and needs less civil works. This difference does not effect the efficiency of the whole system as the doors of the truck are opened inside the refrigerated building achieving a significant energy savings.

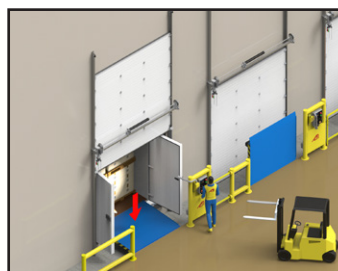
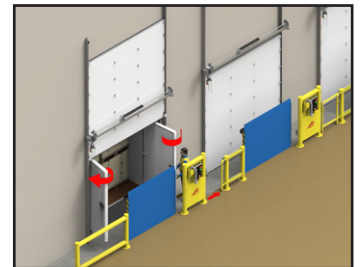
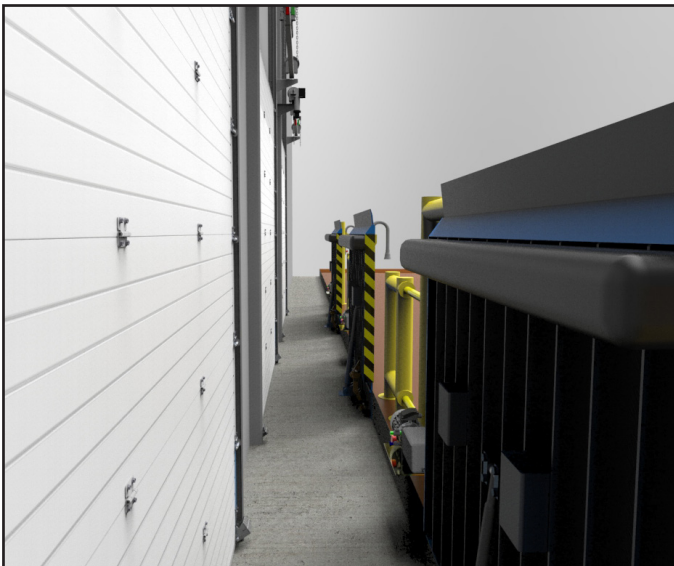

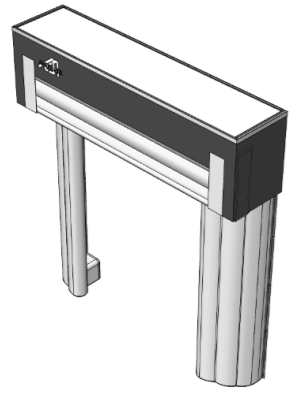

AH ECO 36/40



AH ISO 36/40

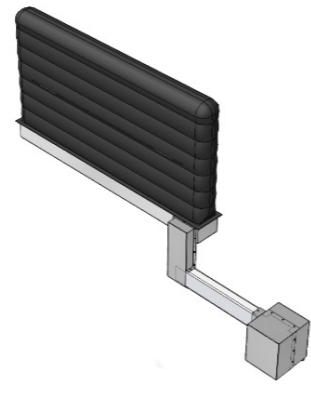

AH 4BAGS

Option:  
- Interchangeable protective coating for vertical cushions  
- Top cushion of 1.500mm or 1.800mm

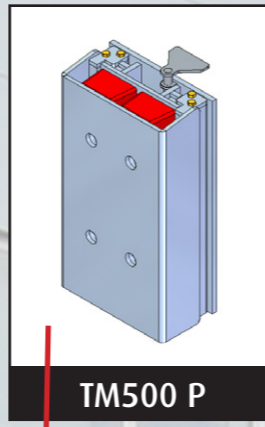

TM500 P

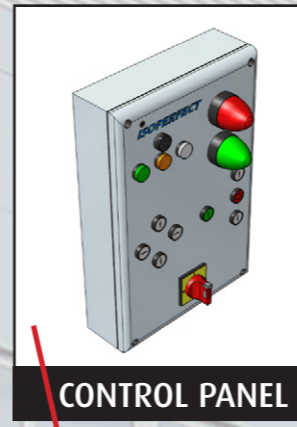

CONTROL PANEL

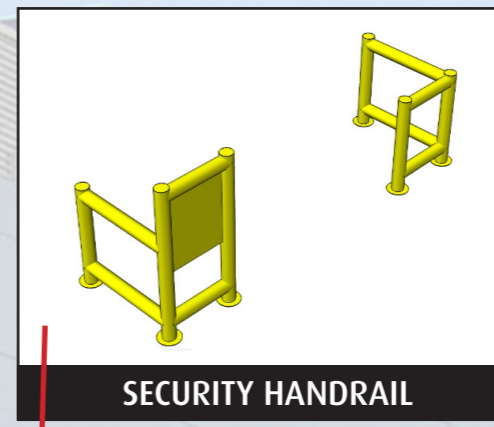

SECURITY HANDRAIL

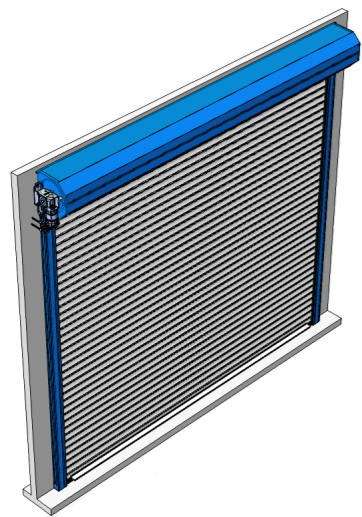

MIRHERM IST ROLLER SHUTTER

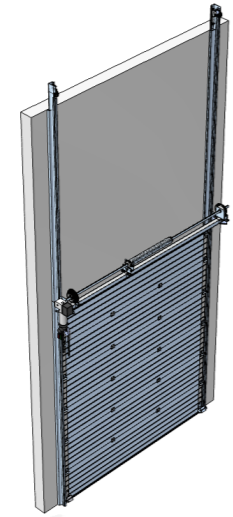

SECTIONAL DOOR  
40mm o 80mm  
Option: stainless steel

Consult models, accessories, sizes and options

Clear width: 3.000 ... 3.200 mm  
Clear height: 3.750 ... 4.000 mm

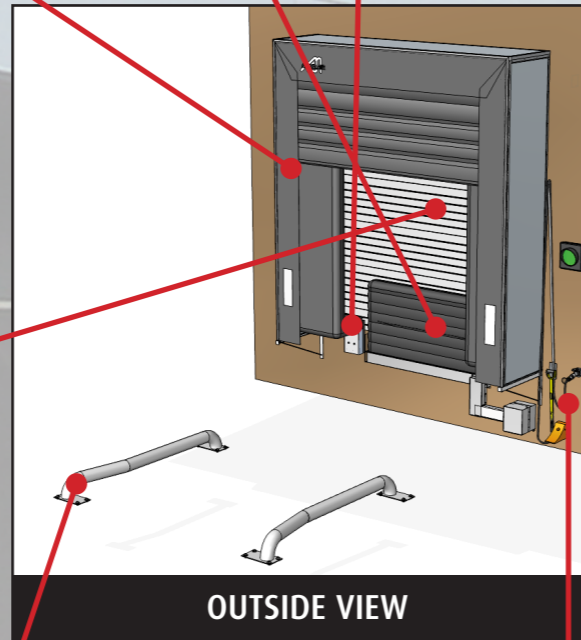

OUTSIDE VIEW

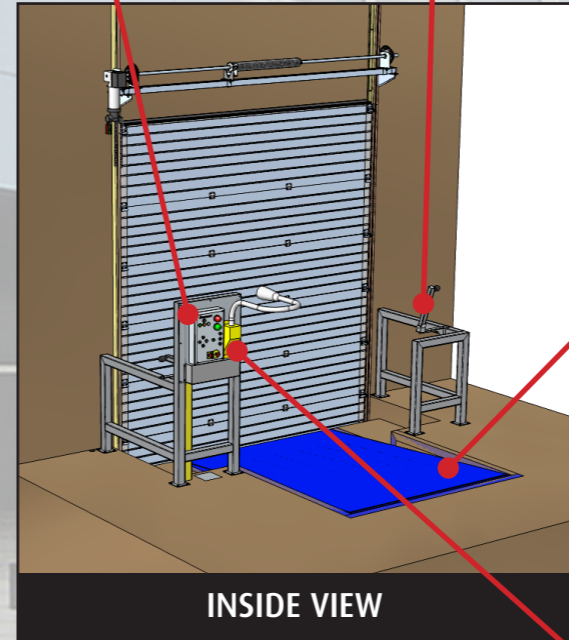

INSIDE VIEW

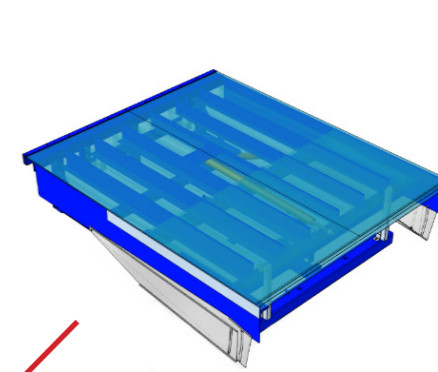

DOCK LEVELLER TELESCO

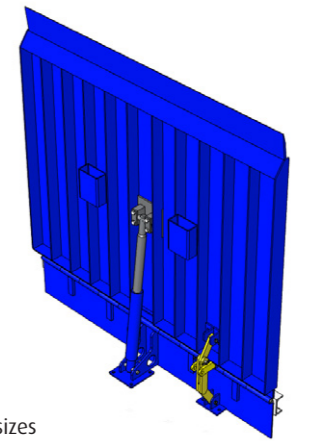

LOADING BRIDGE KA-HIDRA

Consult models and sizes



Hot galvanized steel



Stainless steel



Painted steel with EPOXI RAL 5010



G-15

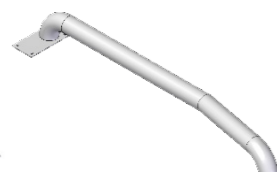

G-25

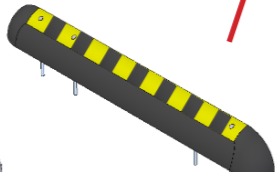

GH-3000



POLYCHOCK

SUPERCHOCK BASIC

SMARTCHOCK



VERSALIGHT



VERSALIGHT MINI

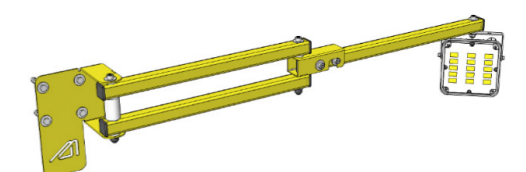

DOCKLIGHT

# Advantages:



1) **ENERGY SAVINGS;** thanks to the thermal sealing of the dock and that the doors open inside the industrial unit, a considerable improvement regarding the energy consumption and the conservation of the environment is achieved.

2) **SAFETY FOR THE STAFF;** to install a safety wedge can prevent the truck from moving and the forklift from falling.

3) **TIME REDUCTION;** it is possible to carry out less manoeuvres with the truck than with a conventional system and the driver does not have to leave the vehicle to open the doors.

4) **FOOD HYGIENE AND SECURITY;** it guarantees greater control of the cold chain and prevents external agents to enter, since the opening of the dock door and the truck one is completed when the inflatable shelter is already sealed to the entire vehicle.

5) **ORGANISATION;** it obliges the operators to follow some rules and routines that ensure compliance with the procedure, therefore minimizing mistakes or avoiding tasks to be duplicated.



Outside and inside view of Isoperfect loading bay in food industry

Opening the back truck doors inside the dock

Inside view of Isoperfect loading docks



Outside and inside view of Isoperfect loading dock with inflatable shelter colour grey



Isoperfect Plus System with 4Bags shelter

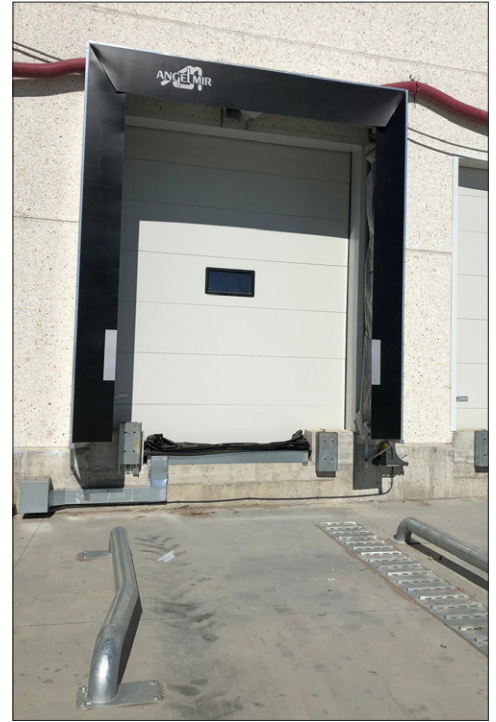



*FIRE RESISTANT DOORS*



*DOCK LEVELLERS*



*SPEED DOORS*



*ROLLER SHUTTER DOORS*



*TRUCK WHEEL CHOCKS*



*MOBILE GROUND RAMPS*



*SECTIONAL DOORS*



*DOCK SHELTERS*



*LIFTING TABLES*



*LOADING HOUSE*



*RIPENING DOORS*



*SPEED SELF-REPAIRING DOORS*

## **INDUSTRIAL DOORS AND LOADING BAY EQUIPMENT**

**PORTES BISBAL SL - ANGEL MIR**

Pol. Ind. Risseç s/n  
17121 Corçà (Girona) - SPAIN  
**T. (34) 972 640 620**  
**Fax: (34) 972 642 541**

[www.angelmir.com](http://www.angelmir.com)  
[info@angelmir.com](mailto:info@angelmir.com)

